

How to play the game "Seven Ball"

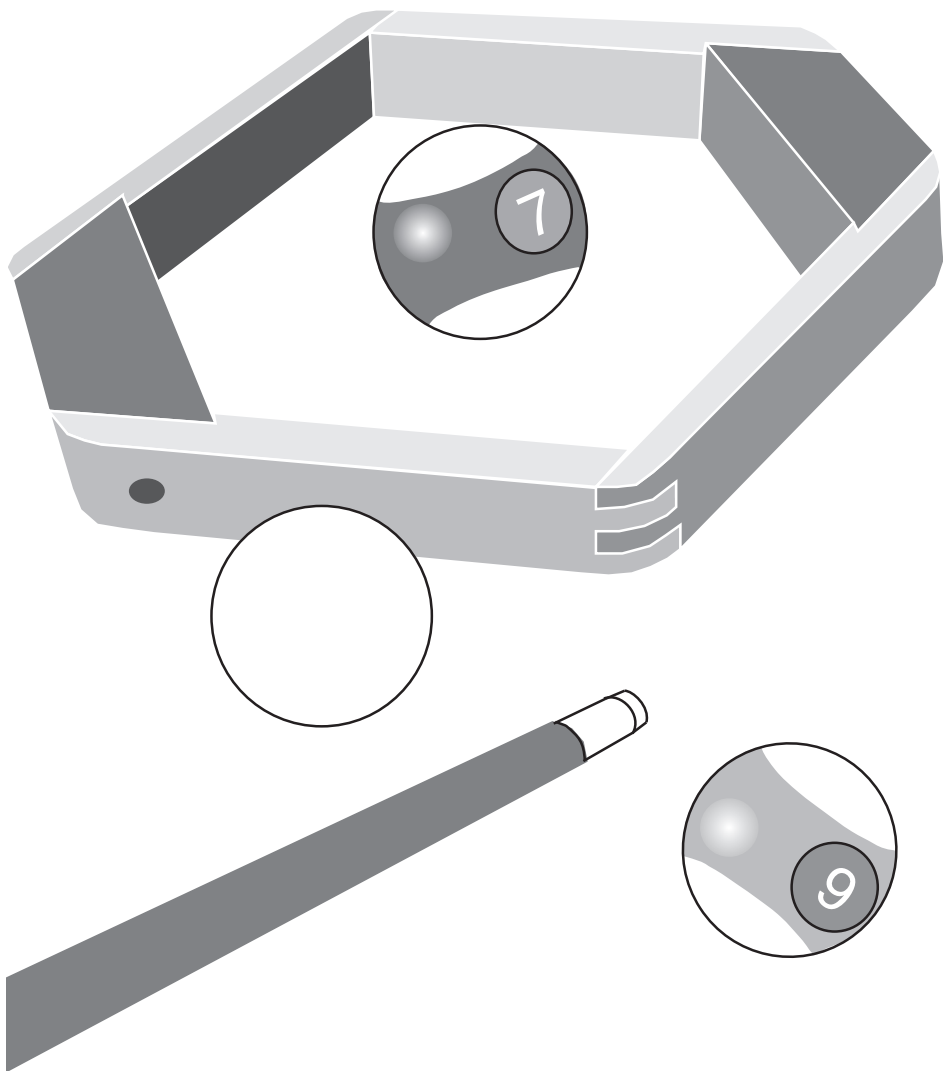

How to play the game "SEVEN BALL"

Except when clearly contradicted by these additional rules, the **General Rules of Pocket Billiards** apply.

Type of Game: Seven Ball is a new, speedy rotational game designed to meet the time requirements of television. Averaging only about three minutes per game because contestants shoot at the same seven object balls, it permits players to show skills in making combination and carom shots, defensive shots and placement. At the same time it is attractive to players of moderate skills, and readily adapts to handicapping by limiting the number of pockets in which the better contestant can legally pocket the game-winning 7 ball. Any nationwide commercial use of this game (patent pending) should be cleared in advance with Big Fights, Inc., 9 East 40th St., New York, New York 10016.

Players: 2 (or 2 teams)

Balls Used: Object balls numbered 1-7, plus cue ball.

The Rack: A special circular rack has been designed for this game. A standard diamond rack (as used in Nine Ball) may also be used by turning it sideways. The balls are racked in a circle on the foot spot, with the 1 ball at the apex (12 o'clock) and the balls increasing numerically 1-6 (clockwise in a circle) with the 7 ball in the middle of the circle. See Diagram.

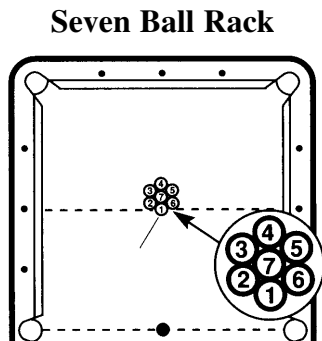

Object of the Game: To legally pocket the 7 ball.

Scoring: The balls have no point value. The player legally pocketing the 7 ball is credited with a game won.

Opening Break: The starting player must (1) make an open break, or (2) legally pocket an object ball. If he/she fails to do so, incoming player has choice of foul Penalty #1, or having the balls reracked and shooting the opening break shot him/herself. In subsequent games players alternate the break shot.

Rules of Play:

1. A legal shot requires that the cue ball's first contact be with the lowest numbered ball on the table. A player must then (1) pocket a ball, or (2) cause the cue ball or any object ball to contact a cushion. Failure to meet these requirements is a foul and four Penalty #2 applies.
2. A legally pocketed ball entitles a shooter to remain at the table until he/she fails to pocket a ball on a legal shot.
3. After a legal opening break, opponent chooses which side of the table (any of the three pockets on one side) into which he/she will pocket the 7 ball. Balls 1-6 may be pocketed on either side of the table.
4. Pocketing the 7 ball on a fair opening break wins the game.
5. Any violation of General Rules results in Penalty #2.

Loss of Game: A player loses the game if he/she commits any of the following infractions: (a) pockets the 7 ball in a non-assigned pocket after the break, (b) scratches when the 7 ball is his/her legal object ball, (c) pockets the 7 ball on an illegal shot, (d) misses when the 7 ball is his/her object ball (optional-an alternative is to assess foul Penalty #2), (e) commits three successive fouls.

Illegally Pocketed Object Balls: All spotted, Penalty #2 applies. (Optional for coin-operated tables: all balls remain pocketed; Penalty #2 applies.)

Jumped Object Balls: All spotted, no penalty.

Cue Ball after Jump or Scratch: Incoming player has cue ball in hand.

Penalty for Fouls: No point penalty. (1) Incoming player has cue ball in hand behind the head string and object balls in position, but if the lowest numbered object ball is also behind head string it must be spotted. (2) Cue ball in hand anywhere on the table.

Variation: Players of unequal ability may be handicapped by assigning them more or less pockets in which they can play the 7 ball. It is suggested that more skilled players shoot the 7 ball into the side pocket on their side of the table. Players may also agree that the 7 ball can be pocketed anywhere on the table.

mueller
RECREATIONAL PRODUCTS
800-627-8888
www.POOLnDARTS.com

A stylized graphic element consisting of a horizontal line that curves downwards at both ends, forming a wide, shallow 'V' or 'U' shape. This graphic is positioned behind the text 'RECREATIONAL PRODUCTS' and '800-627-8888'.